

The Palladium Series Modular Systems are a highly customizable solution that provide you the flexibility to choose the exercise stations and positioning that best suits your facility. Choose from 6 different configurations and 5 available add-on stations to create the Modular System perfectly suited for your specific needs. Further enhance your brand with personalized paint colors and upholstery.

MODULAR FRAME WITH DUAL CABLE CROSSEVERS TMS6000

FEATURES

- **TMS4000** 4-Sided Pod + 2x Cable Crossover with Adjustable Cable Columns
- 2x Multi-Grip Chin Bar Assemblies
- Cable Crossovers available with 170 lb/85 lb (77 kg/39 kg) resistance or 250 lb/125 lb (114 kg/57 kg) resistance weight stacks

STATIONS (UP TO 2)

B SIDE STATIONS (MAX 2 / MIN 1)

- Lat Pulldown **TMS1100** | 210 lb (95 kg) or 310 lb (141 kg)
- Seated Low Row **TMS1200** | 210 lb (95 kg) or 310 lb (141 kg)



6 weight stack configuration
shown with optional front
and rear shrouds

TMS6000 MODULAR SYSTEM



6 WEIGHT STACK CONFIGURATION

(Fits in center of room)

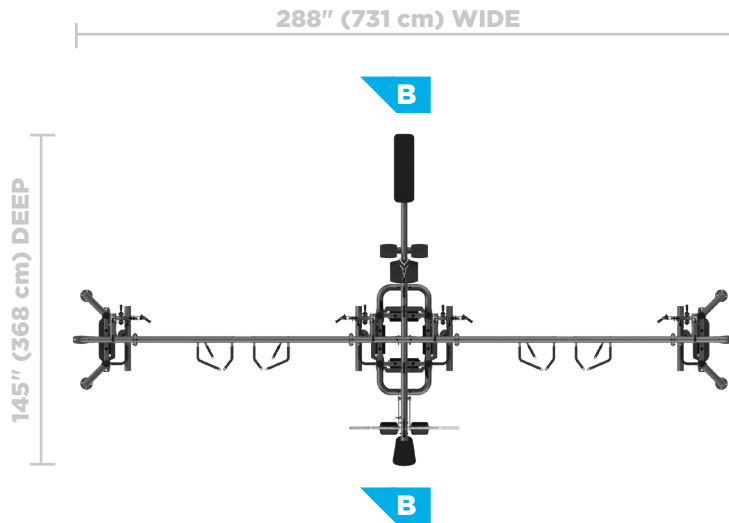

B **SIDE STATIONS**
LAT PULLDOWN
SEATED LOW ROW

6 WEIGHT STACK DIMENSIONS

288" x 145" x 96" / 731 cm x 368 cm x 243 cm

5 WEIGHT STACK DIMENSIONS

288" x 77" x 96" / 731 cm x 196 cm x 243 cm

5 WEIGHT STACK CONFIGURATION

(Fits up against mirror or wall)

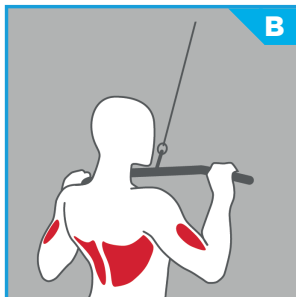
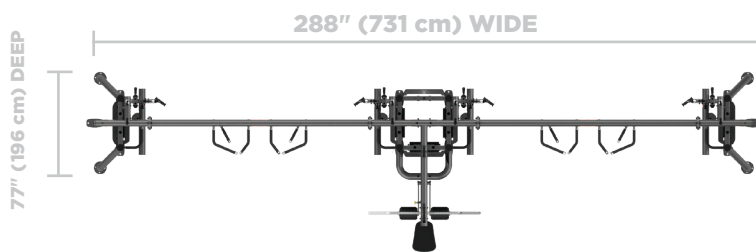

B **LAT PULLDOWN**
TMS1100
Adjustable thigh pad assembly with elevated weight stack for easy access.

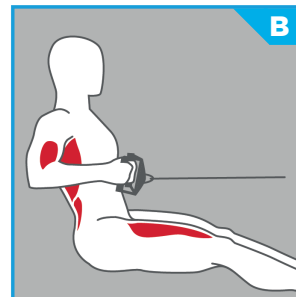

B **SEATED LOW ROW**
TMS1200
Elevated seat position minimizes floor space.



truefitness.com | 800.426.6570 | 636.272.7100

©2021 TRUE Fitness Technology, Inc